

FINZ

High Impact Fan Air Nozzle

DESIGN FEATURES

- Controlled wide uniform distribution and high impact coverage of compressed air
 - Can be mounted individually or side by side for greater coverage
 - Efficient air flow rates with unique eductor feature
 - Safe operation—meets OSHA specifications for noise and deadhead pressure
 - 1/4" male connection is molded to fit either NPT or BSP
 - Up to 2dB quieter than competing designs
- Rugged construction of Ryton® or ABS plastic. Ryton® rated to 300°F (149°C) at 40 psi (3 bar)
 - Maximum operating pressure 100 psi (7 bar)

SPRAY CHARACTERISTICS

Spray patterns: Fan

Air Flow Rates: 4 to 41 SCFM at 10 to 90 psi (7 to 65 Nm³/hr at 0.7 to 6 bar)

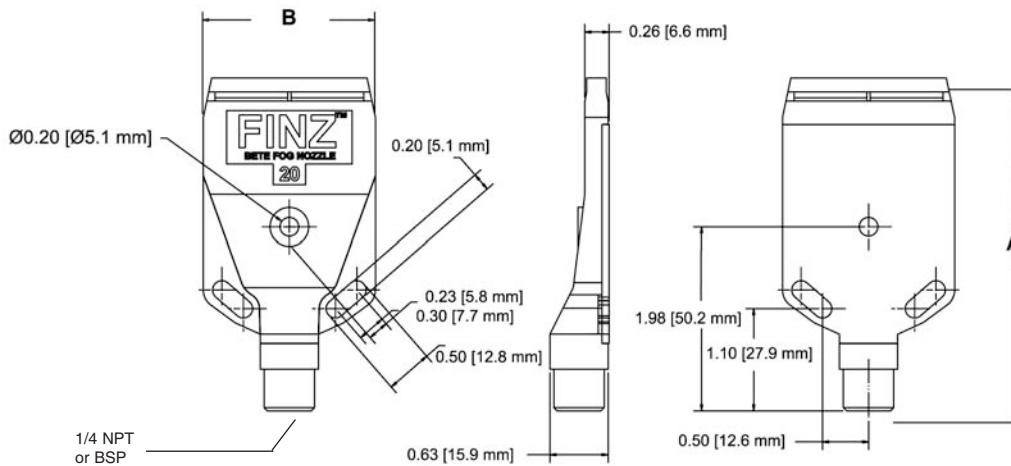

FINZ
High Impact Air Nozzle

Male NPT BSP	Nozzle Number	Air Capacity SCFM				Approx. Dim. in. A B	Wt. (oz.)	Air Capacity Nm ³ /hr				Approx. Dim. (mm) A B		Wt. (g)
		10 PSI	30 PSI	60 PSI	90 PSI			0.7 bar	2 bar	4 bar	6 bar	A	B	
1/4"	FZ20	4	8	12	16	3.58 1.85	1.0	7	12	19	26	91	47	28.3
	FZ29	7	13	21	28			11	21	32	43			
	FZ41	9	18	30	41			15	28	47	65			

Standard Materials: Ryton® and ABS plastic.

Ryton is a trademark of Phillips Petroleum company

SPECIAL PURPOSE

TO ORDER: specify pipe size, connection type, nozzle number and material.